

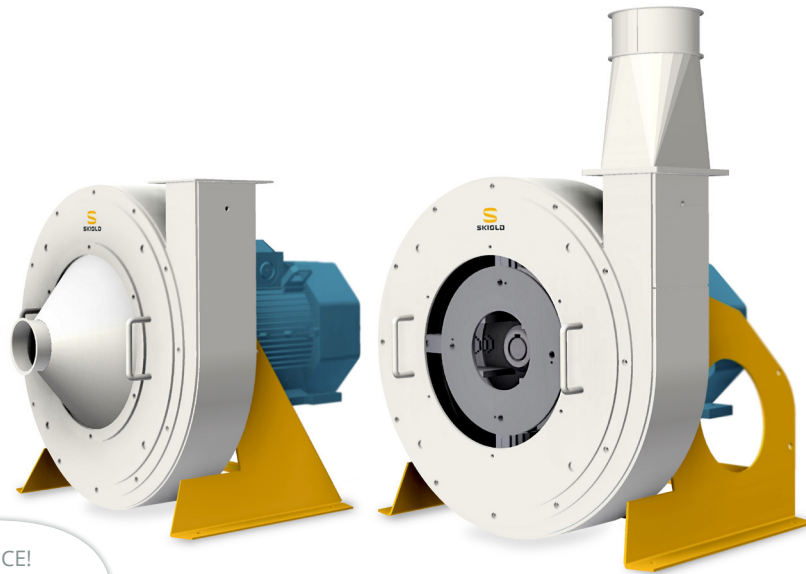

SKIOLD HAMMER MILLS

DM-2 / DM-3 / BM-5



SKIOLD MAKES THE DIFFERENCE!

SKIOLD HAMMER MILLS DM-2 / DM-3 / BM-5

Hammermills with capacities up to 2500 kg/h

Conveying capacities up to 80 meters

Comprehensive range of accessories

Flexible application

Few wearing parts



SKIOLD HAMMER MILL DM-2/DM-3/BM-5

The Hammer Mill

The mills are ideally suited for grinding of animal feed and are supplied complete with a built in fan. This fan enables the raw and ground material to be conveyed throughout the system and has an additional advantage of cooling the meal in the process. The simple but robust construction of the mill enables it to be accommodated into most existing systems.

Wearing Parts

All wearing parts in the mill are easily replaced by original SKIOLD parts. The wearing parts are made of quality material which ensures that servicing of the mill is kept to a minimum. Constant research into prolonging the durability of the parts is carried out as well as constant surveillance of new raw materials as they become available on the market.

Milling

The structure of the ground material depends primarily on the screen size, but also on the raw material. For example wheat is easier to grind than barley. Therefore when using the same screen size for both wheat and barley, the result will be a much finer structure on wheat.

The water content in the grain also influences on the structure - the more saturated material, the coarser structure. Oats is especially difficult to grind and will often after grinding contain large quantities of whole shell parts which makes it difficult for the feed to flow through the silos.

Conveying

The built in fan of the mill enables raw and ground material to be conveyed throughout the system. The conveying capacity depends on the motor size and the number of fan wings in the mill. At installation it must be considered that the mill capacity to blow is better than its capacity to suck. The indicated conveying lengths are horizontal lengths. At calculation the vertical ascent should be counted twice and each bend counted as 3 m. The air quantity in the system is adjusted with the throttle in the feeding device and at the cyclone.

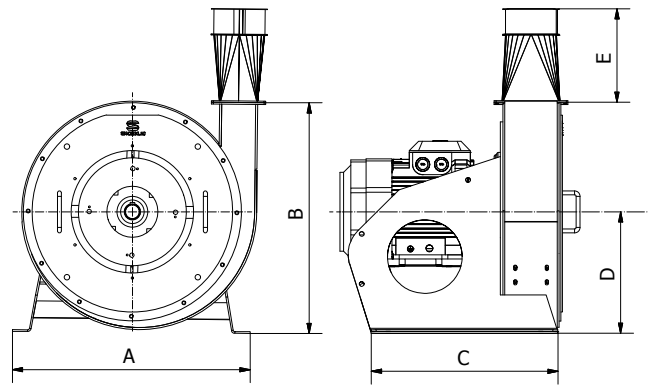

MILLING CAPACITY

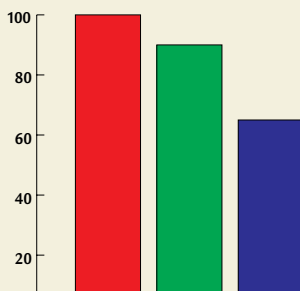

Water content

DIMENSIONS, MM

	A	B	C	D	E
DM-2*	700	675	430	355	225
DM-3	700	679	430	355	277,5
BM-5	1000	810	1000	450	700

* also DME extra fan

TECHNICAL SPECIFICATIONS

Mill type / number of wings	DM-2/2	DM-2/4	DM-3/4	DM-3/8	BM-5/8
Suction pipe - front (Ø mm)	80	80	100	100	120/150
Blowing pipe (Ø mm)	100	100	120	120	150
Air speed (m/sec.)	20	20	20	20	20
Airflow (m ³ /h)	565	565	815	815	1000
Max. air pressure (mm WC)	160	275	450	540	450
Min. filter area (m ²)	9	9	15	15	30
Min. filter area (Ø 200, m)	12	12	24	24	50
Motor (kW)	5,5-7,5	5,5-7,5	11-18,5	11-18,5	37